

RING VAC™

Convey solid materials, waste, trim, small parts with virtually no moving parts

WHAT ARE THEY - REASONS TO USE

The Ring Vac™ - Pneumatic Conveying System has virtually no moving parts, conveys material at high rates and over long distances. They utilize only compressed air for a powerful, efficient venturi action along its length in a compact design for high capacity conveying over large distances. Ring Vacs are available in both coated aluminum or stainless steel. Simply clamp a standard hose size to each end of the Ring Vac™ to create this high energy conveying system. Threaded versions may be connected into standard pipe thread. No moving parts for maintenance free operation with capacity and flow controlled with a pressure regulator. Sizes are 3/8" (10mm), 1/2" (13mm), 3/4" (19mm), 1" (24.4mm), 1-1/4" (32mm), 1-1/2" (38mm) and 2" (51mm) and 3" (76.2mm). Any size beyond that can be prohibitive for most applications due to high compressed air requirements.

Beyond 3", the vacuum ability begins to drop significantly except for highly intermittent applications. However 3" units are available for such applications. Larger sizes are available on special order.

Anodized aluminum and high temperature stainless steel Ring Vac™ air conveyor can convey all types of solids in large volumes over great distances with no moving parts.

APPLICATIONS:

- ▶ Hopper Loading
- ▶ Material Conveying
- ▶ Trim Removal
- ▶ Transfer Parts
- ▶ Filling Operations
- ▶ Thread/fiber Tensioning

RING VAC™ BENEFITS:

- ▶ Longer life in difficult environments than competitive models.
- ▶ Ease of use.
- ▶ Simple and easy control of material flow.
- ▶ Maintenance free operation.

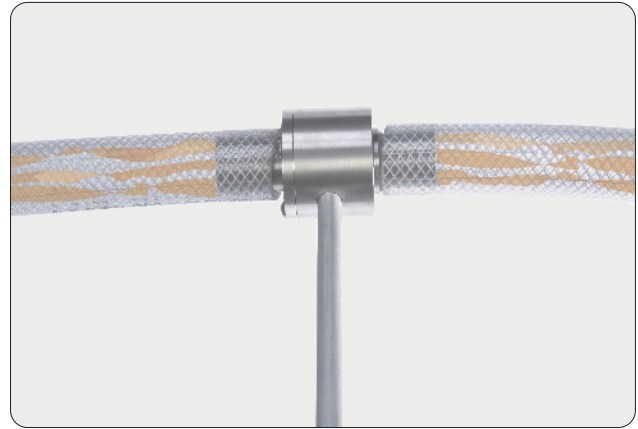

RING VAC™ FEATURES:

- ▶ Made of anodized aluminum with no moving parts. Regular and high temperature stainless steel models are available for higher temperature and corrosive environments.
- ▶ Standard sizes to fit standard hose diameter for easy clamping. Threaded versions connect easily to regular pipe thread : 1" (25mm), 1-1/4" (32mm), 1-1/2" (38mm), 2" (51mm). Special sizes can be manufactured if required.
- ▶ Utilizing a pressure regulator will control the flow material.
- ▶ Instant on/off with no moving parts, no electricity or explosion hazard.

A Model 30004S Stainless Steel 2" Ring Vac™ Air operated conveyor moves dried peas at a pet food manufacturing facility.

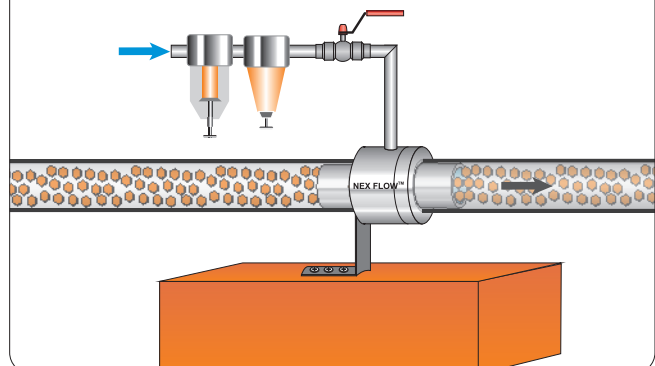

DIMENSIONS - NOTES ON PART NUMBERS:

S - stainless TS - threaded stainless THTS - high temperature threaded stainless
 T - threaded HTS - high temperature stainless

Dimensions in inches and (mm)

PART NUMBER (aluminum & stainless)	A IN (MM)	B IN (MM)	C IN (MM)	D IN (MM)	E IN (MM)	F IN (MM)	G IN (MM)	H IN (MM)	I IN (MM)	J IN (MM)	K IN (MM)	L
39998, 39998S 39998HTS	0.375" (10.0)	0.63" (16.0)	0.63" (16.0)	2.18" (65.0)	1.00" (25.0)	0.19" (5.0)	-	-	-	-	-	1/8" NPT
39999, 39999S 39999HTS	0.50" (13.0)	0.75" (19.0)	0.75" (25.4)	2.62" (19.0)	1.25" (32.0)	0.31" (8.0)	-	-	-	-	-	1/8" NPT
30000, 30000S, 30000HTS, 30000S-316L, 30000HTS-316L	0.75" (19.0)	1.00" (25.4)	1.00" (25.4)	3.94" (100.0)	1.95" (49.5)	0.55" (14.0)	1.92" (48.73)	0.95" (15.0)	0.39" (10.0)	1.18" (30.0)	1.97" (50.0)	1/4" NPT
30001, 30001S, 30001T 30001TS, 30001HTS 30001THTS, 30001S-316L 30001HTS-316L	1.00" (25.4)	1.38" (35.1)	1.50" (38.1)	4.88" (124.0)	2.24" (56.8)	0.75" (19.0)	2.17" (55.0)	0.73" (18.5)	0.39" (10.0)	1.58" (40.0)	1.97" (50.0)	1/4" NPT
30002, 30002S, 30002T 30002TS, 30002HTS 30002THTS, 30002S-316L 30002HTS-316L	1.25" (31.8)	1.38" (35.1)	1.50" (38.1)	4.88" (124.0)	2.49" (63.2)	1.00" (25.4)	2.21" (56.3)	0.73" (18.5)	0.39" (10.0)	1.77" (45.0)	2.17" (55.0)	1/4" NPT
30003, 30003S, 30003T 30003TS, 30003HTS 30003THTS, 30003S-316L 30003HTS-316L	1.50" (38.1)	1.38" (35.1)	1.50" (38.1)	4.88" (124.0)	2.75" (69.9)	1.125" (28.6)	2.15" (54.5)	0.89" (22.5)	0.39" (10.0)	1.58" (40.0)	1.97" (50.0)	3/8" NPT
30004, 30004S, 30004T 30004TS, 30004HTS 30004THTS, 30004S-316L 30004HTS-316L	2.00" (50.8)	1.38" (35.1)	1.50" (38.1)	4.88" (124.0)	3.21" (81.6)	1.75" (44.5)	2.39" (60.7)	1.18" (30.0)	0.39" (10.0)	1.58" (40.0)	1.97" (50.0)	3/8" NPT
30005, 30005S 30005HTS	2.50" (63.5)	1.38" (35.1)	1.50" (38.1)	5.29" (134.5)	3.94" (100.0)	2.19" (55.6)	-	-	-	-	-	3/8" NPT
30006, 30006S 30006TS, 30006HTS 30006THTS	3.0" (76.2)	1.58" (40.0)	1.58" (40.0)	5.59" (142.0)	4.33" (110.0)	2.68" (68.0)	-	-	-	-	-	1/2" NPT

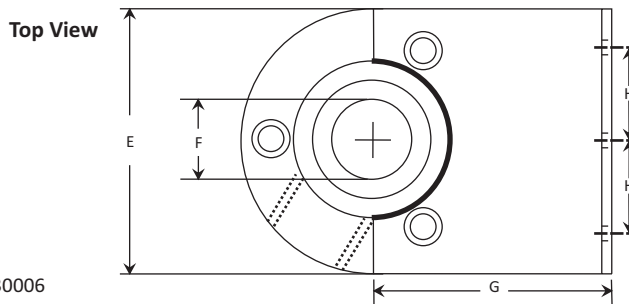

Series 30000 - 30006
Series 30001S - 30004S

Series 30001T - 30004T Threaded
Series 30001TS - 30004TS Threaded

